

SECTION C-C  
SCALE 1 : 2

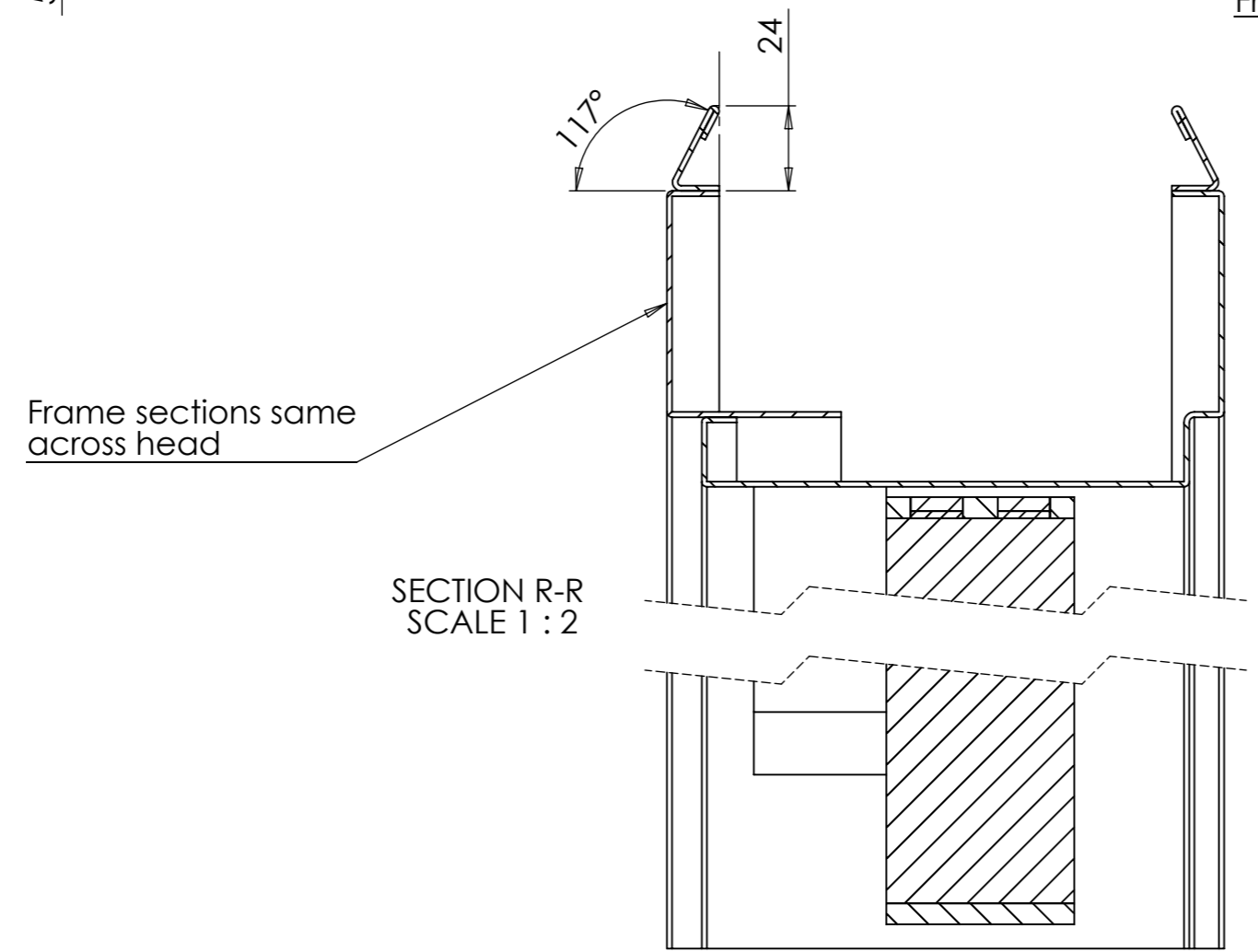

SECTION R-R  
SCALE 1 : 2

Frame Part 2

Architrave Depth.  
Default to be 15mm  
If Wall Depth is <130mm  
increase architrave  
depth equally.  
  
Example: 120mm Wall depth  
frame would have 20mm  
architrave depth

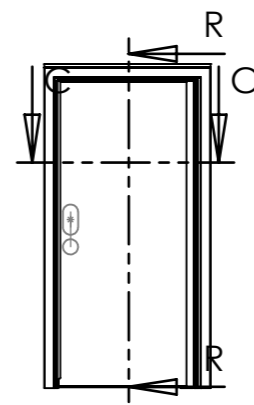

PART #:	TBA	<b>SAFEHINGE</b> SIMPLY DIFFERENT
DESCRIPTION:	Swiffit frame	
MATERIAL:	Mild Steel	01412440085
SURFACE FINISH:	Powdercoat (RAL)	PROPRIETARY AND CONFIDENTIAL THE INFORMATION CONTAINED IN THIS DRAWING IS THE SOLE PROPERTY OF SAFEHINGE LTD. ANY REPRODUCTION IN PART OR AS A WHOLE WITHOUT THE WRITTEN PERMISSION OF SAFEHINGE LTD IS PROHIBITED.
PROJECT:	BIM	© 2014 SAFEHINGE LTD
UNLESS OTHERWISE SPECIFIED: DIMENSIONS ARE IN MILLIMETERS		3RD ANGLE PROJECTION
TOLERANCES: LINEAR: ±0.25 ANGULAR: ±0.75°		DRAWN BY: S Ridley DATE: 3/6/15 CHECKED BY: DATE:
DEBUR AND BREAK ALL SHARP EDGES		REV:
SCALE:1:20 SHEET 1 OF 4 DO NOT SCALE DRAWING		A3

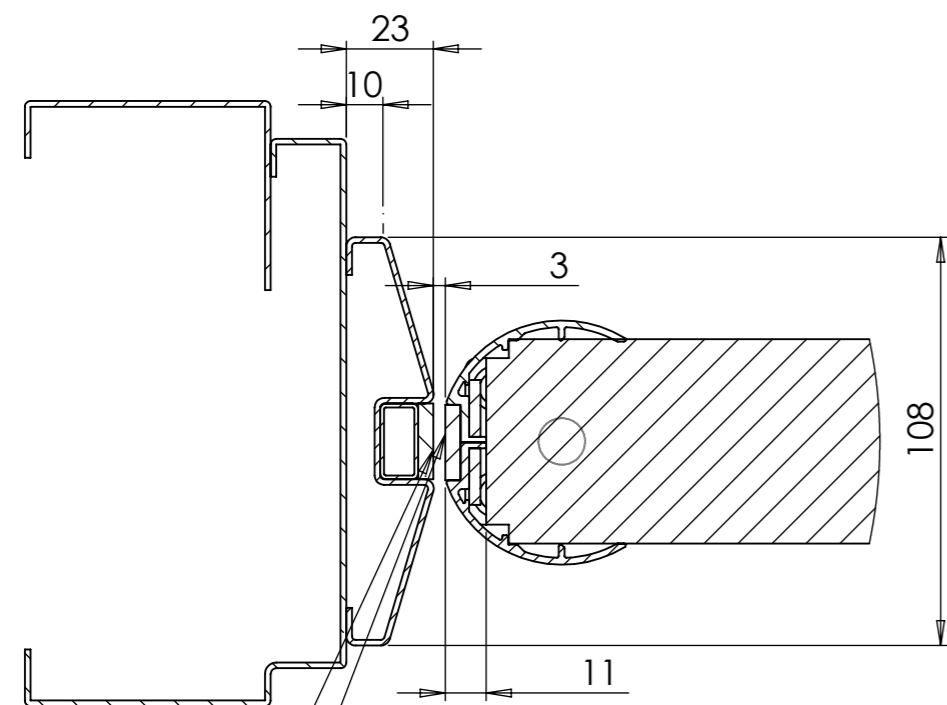

Intumescent  
20x4mm

Intumescent  
20x4mm

**Add-on Detail**  
DETAIL G  
SCALE 1 : 2

**Movastop Doorstop**

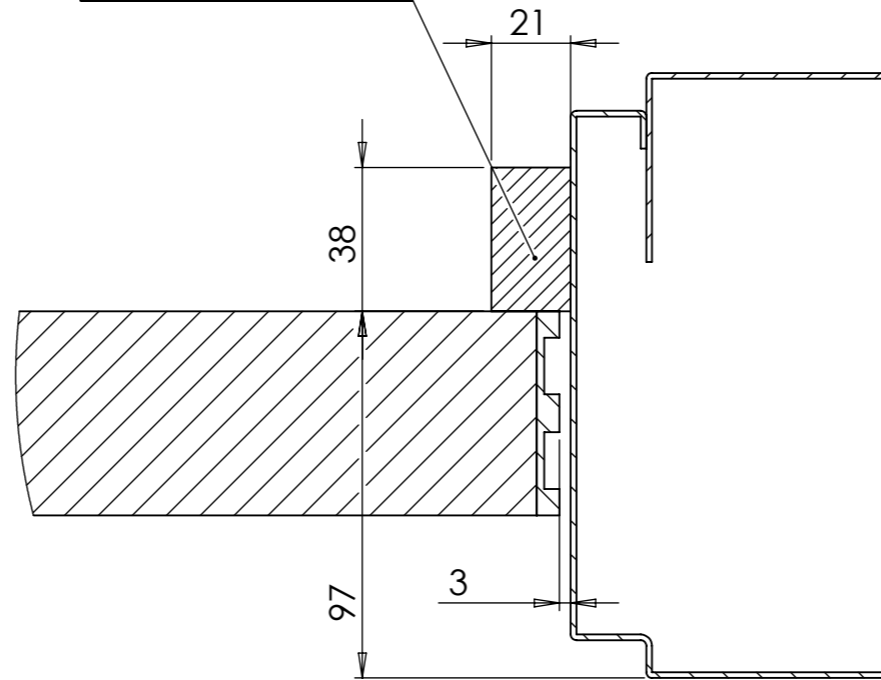

DETAIL H  
SCALE 1 : 2

**Swiftstop**

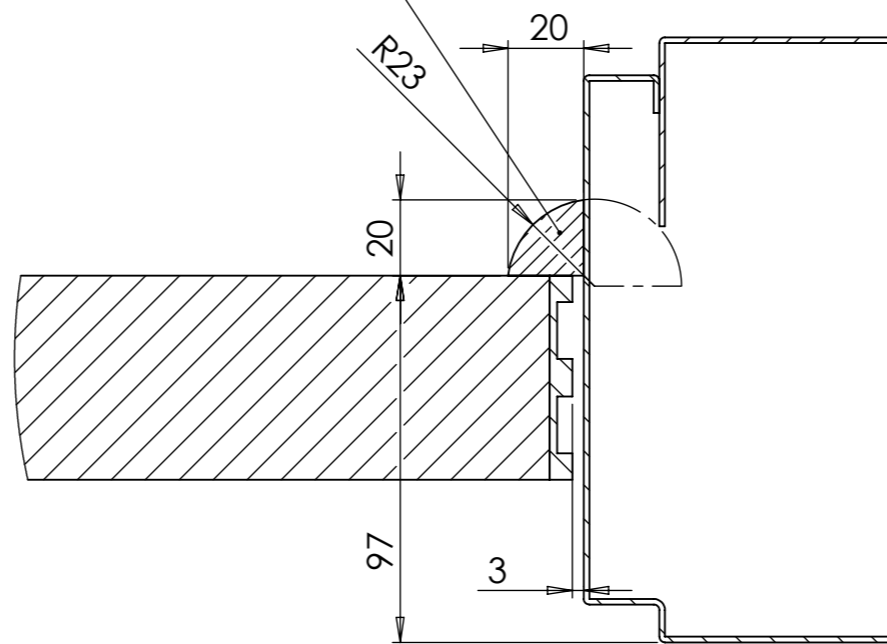

DETAIL M  
SCALE 1 : 2

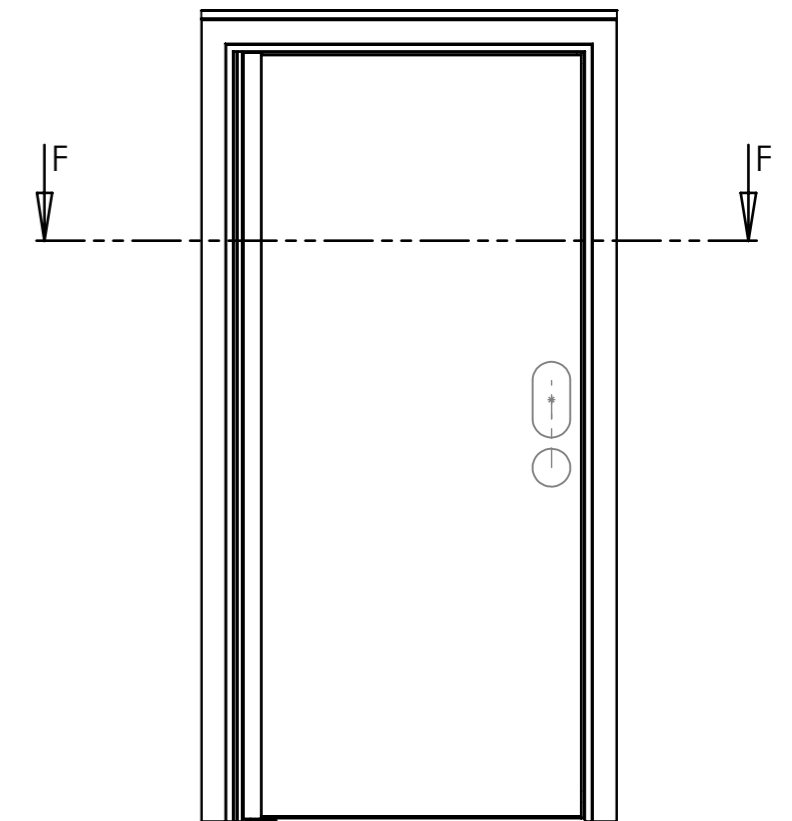
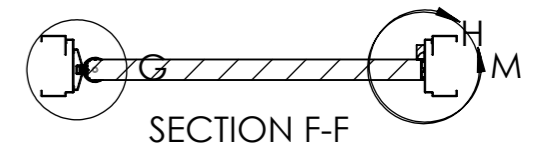

PART #:			<b>SAFEHINGE</b> SIMPLY DIFFERENT
DESCRIPTION:			
MATERIAL:			01412440085
SURFACE FINISH:			PROPRIETARY AND CONFIDENTIAL THE INFORMATION CONTAINED IN THIS DRAWING IS THE SOLE PROPERTY OF SAFEHINGE LTD. ANY REPRODUCTION IN PART OR AS A WHOLE WITHOUT THE WRITTEN PERMISSION OF SAFEHINGE LTD IS PROHIBITED.
PROJECT:			© 2014 SAFEHINGE LTD
UNLESS OTHERWISE SPECIFIED: DIMENSIONS ARE IN MILLIMETERS			3RD ANGLE PROJECTION
<b>TOLERANCES:</b> LINEAR: ±0.25 ANGULAR: ±0.75°			DRAWN BY: DATE: CHECKED BY: DATE:
DEBUR AND BREAK ALL SHARP EDGES			REV:
SCALE: 1:20	SHEET 2 OF 4	DO NOT SCALE DRAWING	A3

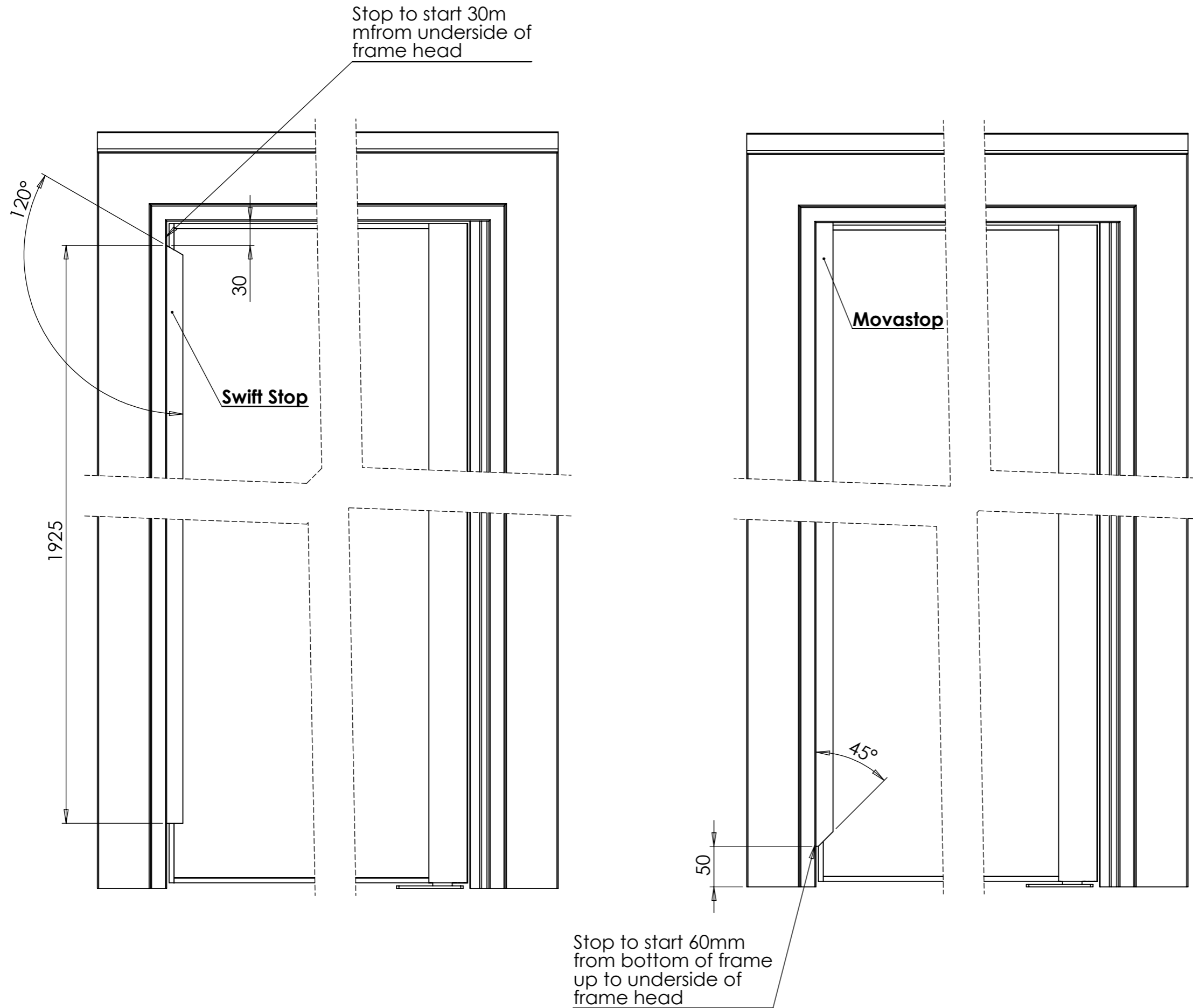

PART #:	TBA	
DESCRIPTION:	Swiftfit Frame	
MATERIAL:	Mild Steel	PROPRIETARY AND CONFIDENTIAL THE INFORMATION CONTAINED IN THIS DRAWING IS THE SOLE PROPERTY OF SAFEHINGE LTD. ANY REPRODUCTION IN PART OR AS A WHOLE WITHOUT THE WRITTEN PERMISSION OF SAFEHINGE LTD IS PROHIBITED.
SURFACE FINISH:	Powdercoat (RAL)	© 2014 SAFEHINGE LTD
PROJECT:	BIM	
UNLESS OTHERWISE SPECIFIED: DIMENSIONS ARE IN MILLIMETERS		DRAWN BY: S Ridley DATE: 2/6/15 CHECKED BY: DATE:
TOLERANCES: LINEAR: ±0.25 ANGULAR: ±0.75°		REV:
DEBUR AND BREAK ALL SHARP EDGES		A3
SCALE: 1:20	SHEET 3 OF 4	DO NOT SCALE DRAWING

Coverplate for Transom closer  
 RTS87 = 105x320mm  
 EMB/Freeswing = 105x358mm

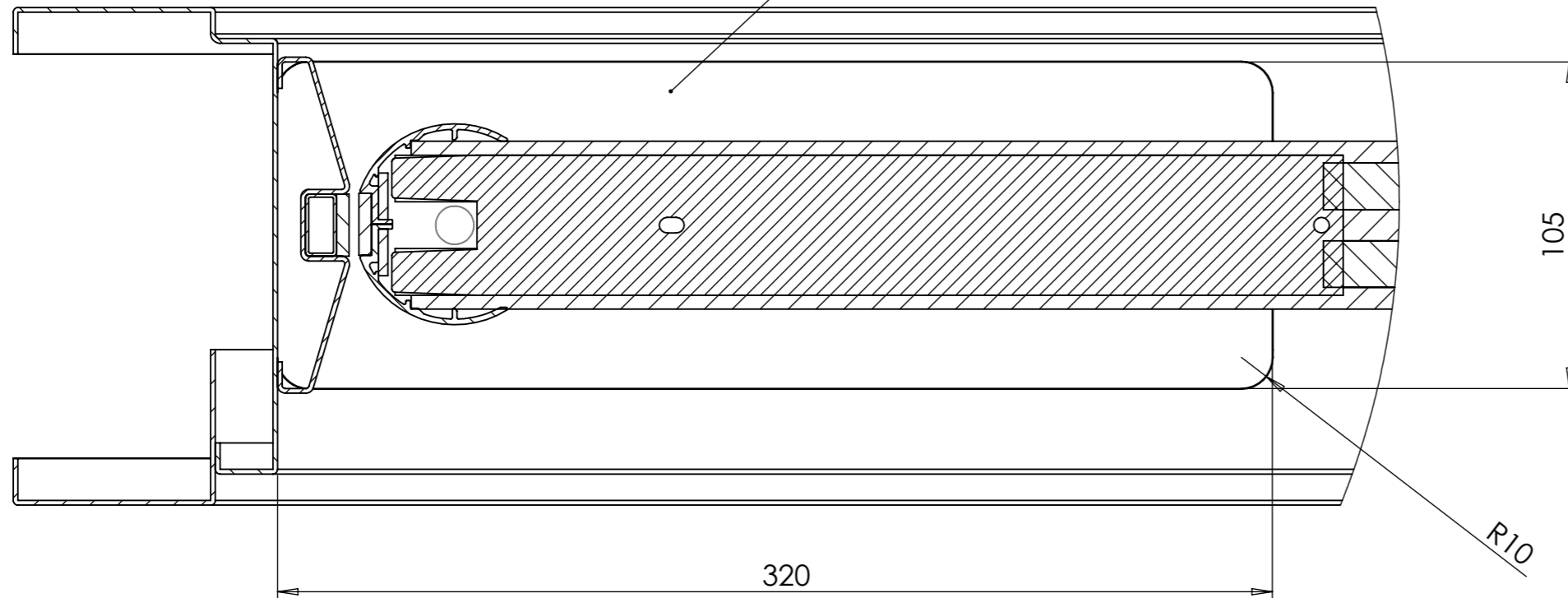

DETAIL P  
 SCALE 1 : 2

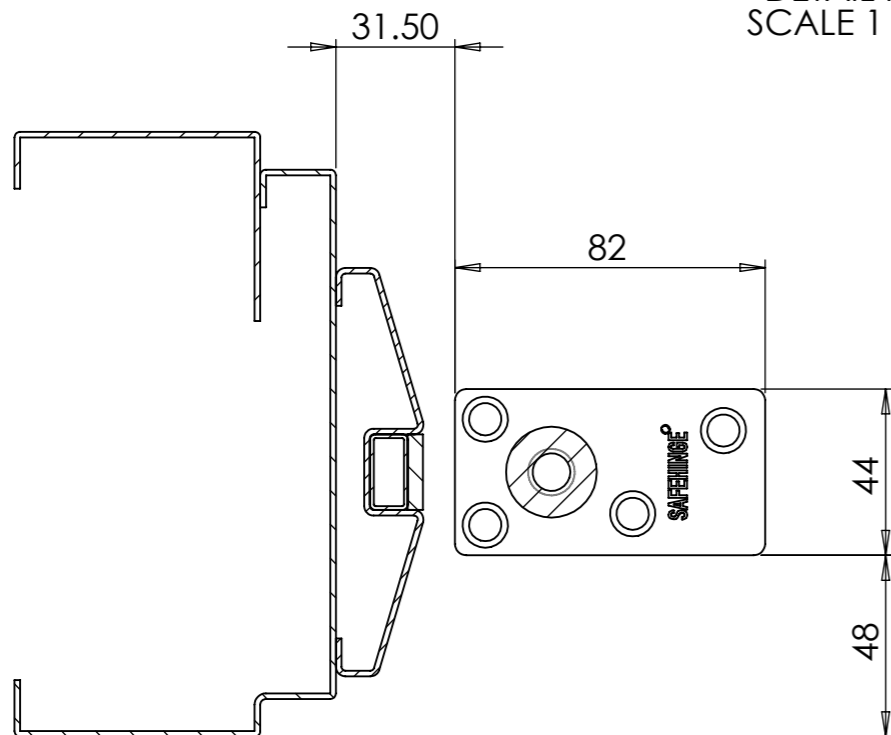

DETAIL Q  
 SCALE 1 : 2

SECTION N-N

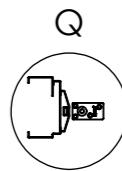
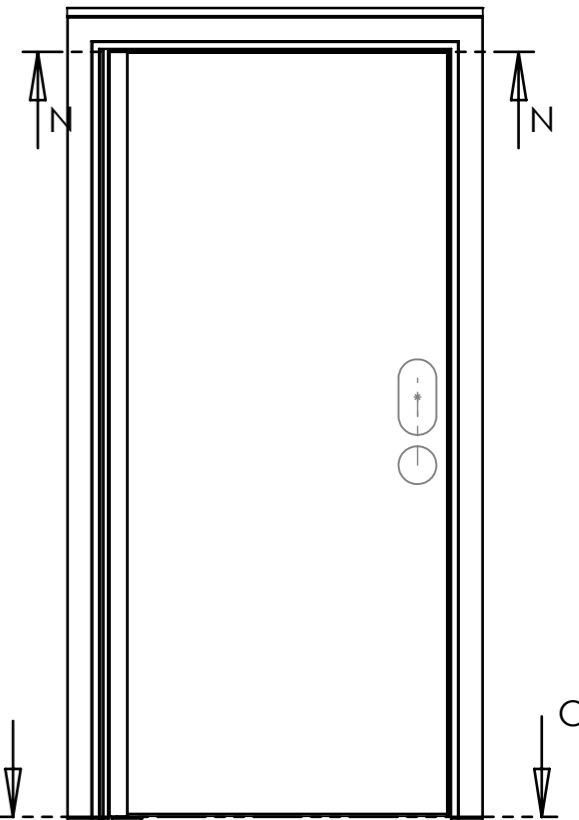
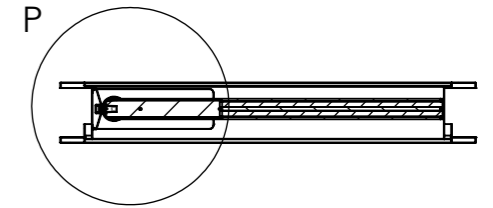

SECTION O-O

PART #:	TBA	
DESCRIPTION:	Swiftfit Frame	
MATERIAL:	Mild Steel	01412440085 PROPRIETARY AND CONFIDENTIAL THE INFORMATION CONTAINED IN THIS DRAWING IS THE SOLE PROPERTY OF SAFEHINGE LTD. ANY REPRODUCTION IN PART OR AS A WHOLE WITHOUT THE WRITTEN PERMISSION OF SAFEHINGE LTD IS PROHIBITED.
SURFACE FINISH:	Powdercoat (RAL)	© 2014 SAFEHINGE LTD 
PROJECT:	BIM	DRAWN BY: S Ridley DATE: 2/6/15 CHECKED BY: DATE:
UNLESS OTHERWISE SPECIFIED: DIMENSIONS ARE IN MILLIMETERS <b>TOLERANCES:</b> LINEAR: ±0.25 ANGULAR: ±0.75°	DEBUR AND BREAK ALL SHARP EDGES SCALE: 1:20 SHEET 4 OF 4 DO NOT SCALE DRAWING	REV: A3