

Movastop Quick Release Anti-Barricade Removable Doorstop

Installation Instructions (PR-7414-BRDS-LL-WF & PR-7415-BRDS-LL-OF)

Contents		
Item		Quantity
1	Aluminium Doorstop Assembly	x 1
2	Stainless Steel Frame Plate	x 1
3	Top End Cap (Fitted)	x 1
4	Bottom End Cap (Unfitted)	x 1
5	Bottom End Cap Screw Covers	x 2
6	Security Screws for Bottom End Cap	x 2
7	3/4" x 6 C/S Frame Plate Woodscrews	x 30

Note: A Life-Line Key is required when installing this product (not supplied)

Tools Required	
Drill	Combination Square
Hacksaw/Chopsaw	Chisel
PZ2 Screwdriver	Straight Edge
22mm Drill Bit	File
Pencil	T15 Pin Torx Bit
Tape Measure	

= Mark With Pencil
 = Drill Pilot Hole

Important Note:

This is not a DIY product. It is an important life preserving device and should only be installed by suitably qualified trades-people properly equipped to carry out a professional installation.

Setting Up

A. Unpack contents of package. Do not disassemble any components at this stage.

B. Measure door frame head to floor as shown at Fig 1 and deduct 40mm in total (to allow 28mm for the bottom end cap and 12mm clearance). Measuring from the top of the assembly transfer the size to the face side of the Movastop and mark using a pencil and combination square (H - 40mm). The 12mm is critical to ensure that the Doorstop can be removed in an emergency.

C. Using a good quality hacksaw or chopsaw, carefully cut through the aluminium to the correct length ensuring the cut is square and true. Remove any burring with a file.

D. The bottom end cap can now be fixed using the security screws provided. Finish the end cap installation by pushing the screw cover caps into place Inset 2.

Installation

- Using a Life-Line key release lever mechanism Fig 2 - Inset 1.
- Move lever through 90° to release the stainless steel Frame Plate Fig 2 - Item 2 and carefully set aside. **Note: Please handle the Frame Plate with extreme care to prevent bending (hold vertically/store on flat surface).**

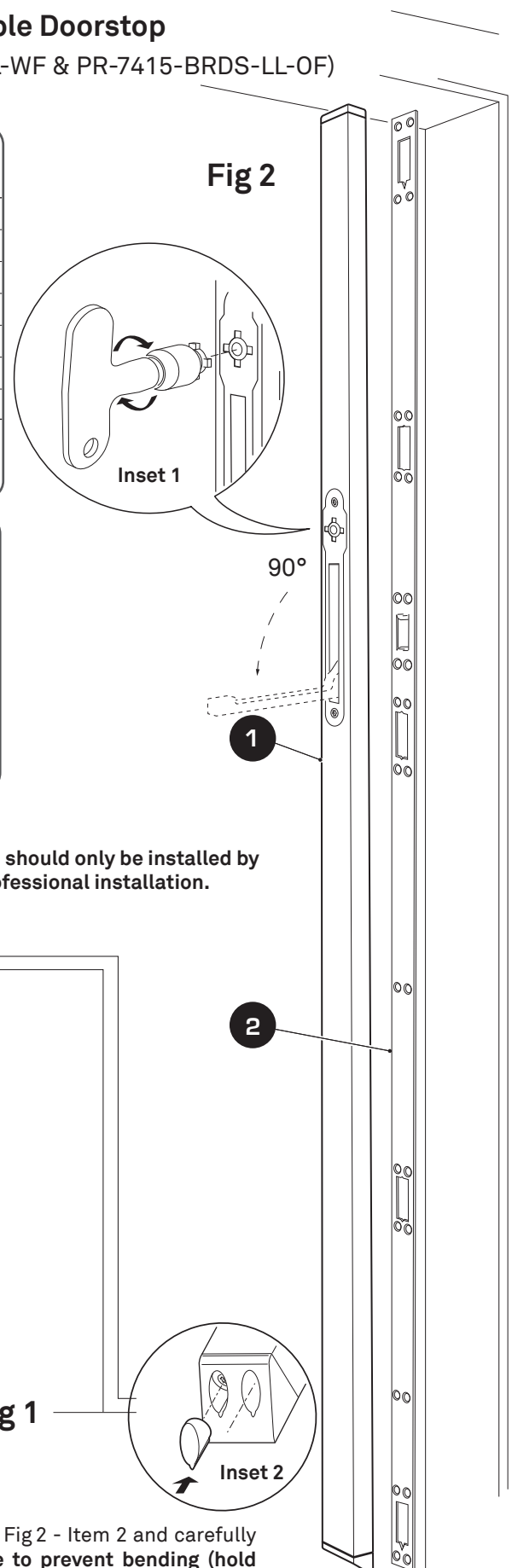

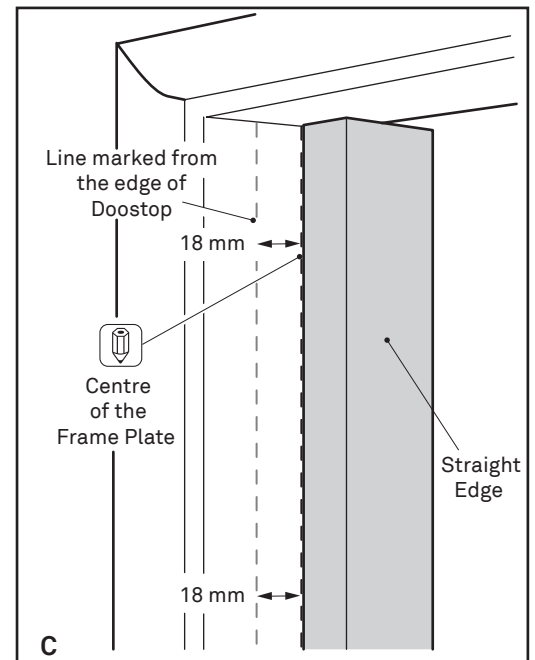

Installation (cont).

3. Offer the Doorstop face side to the frame against the locked door and frame. Apply light pressure against the Doorstop ensuring continuous contact with the door and frame and mark a pencil line all the way down the door lining as shown at Fig B. Now carefully set aside the doorstop

4. From the pencil line, mark a parallel line down the door lining 18mm (not 19mm) in towards the door representing the centreline of the Doorstop as shown at Fig C.

5. Reverse the Frame Plate so that the lips are outward facing and accurately position over the centre line, using the V notches on the frame plate for alignment. Ensure the plate is firmly pushed tight to the head of door frame and hold in place using one of the 3/4" x 6 C/S woodscrews provided. Use a pencil to mark the five lug and the 1 lever recesses as illustrated at Fig D. Remove the plate and carefully set aside.

6. Mark an additional pencil line 12mm above each of the five lug recesses as illustrated at Fig E. Ensure the mortice is square and clean so the lug doesn't snag.

7. Then mark additional pencil lines 5mm above and below the lever recess

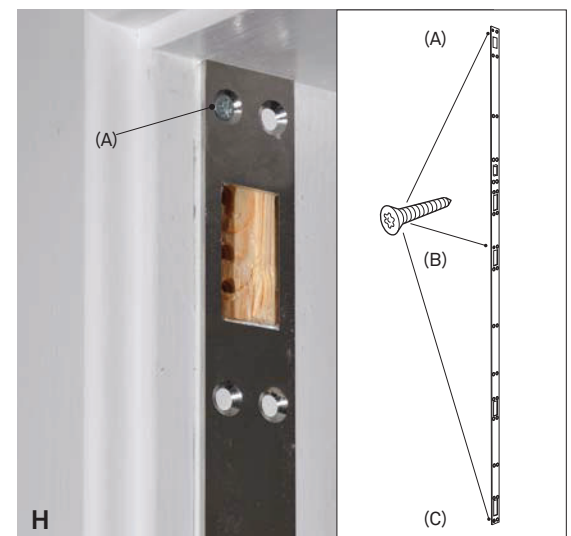
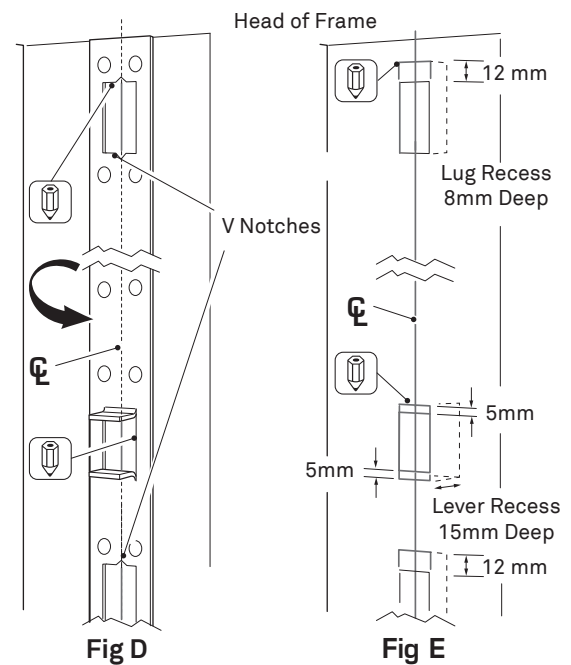

8. Using a suitable 22mm bit, carefully drill each of the five lug recesses to a depth of 8mm See Fig F1 & F2.

9. Then, drill the lever recess to a depth of 15mm.

10. Neatly square out each recess using a sharp chisel removing any splinters or debris which might hinder/prevent the movement of the Doorstop as shown at Fig G.

11. Now, with the lips pointed towards the door lining, offer the SS Frame Plate back in to position using the V notches on the frame plate to realign to the centre line mark, hold in position using 3 No 3/4" x 6 C/S woodscrews (top, middle and bottom) as illustrated in Fig H.



12. Offer the Doorstop on to the Frame Plate as shown at Fig I and re-lock by pushing the lever upright until it snap-locks into position. To check function and alignment use the Life-Line key to operate. Adjust accordingly ensuring that the door lock functions properly. Afterwards, remove the Doorstop and fully secure the Frame Plate to the door lining with the remaining ¼” x 6 C/S woodscrews provided.

13. Un-lock / re-lock the Doorstop several times to ensure it still functions properly. There should be a smooth operation with no friction between the Doorstop and the Frame Plate and there should be no gap between the top of the doorstop and the head of the frame .

Troubleshooting

Symptom	Possible Cause	Suggested Action
Lever is stiff.	Obstacle in lug or lever recesses.	Check all recesses are clear and free from debris.
	Frame plate is bowed laterally.	Check and re-align accordingly.
	Too much friction between the Doorstop and door surface.	Check and re-align Frame Plate.
Doorstop won't locate.	Inaccurate position of Frame Plate.	Check and re-align.
	Insufficient clearance in lug or lever recesses.	Ensure adequate clearance in all recesses to enable free movement of lugs/lever.
Doorstop won't release.	Obstacle jammed underneath chamfered tip at bottom of Doorstop preventing downward movement to enable release.	Clear obstacle.
Door Lock not working as before.	Too much friction between dead-bolt and strike caused by misalignment of Frame Plate.	Reposition Frame Plate accordingly (steps 1-3 inclusive).

Further Information:

For further advice on the Primera PR-7412-BRDS Quick Release Removable Doorstop please contact our Technical Help-Line: 0330 058 0988.

MOVASTOP - FACTORY PREPARATION FRAME DETAIL

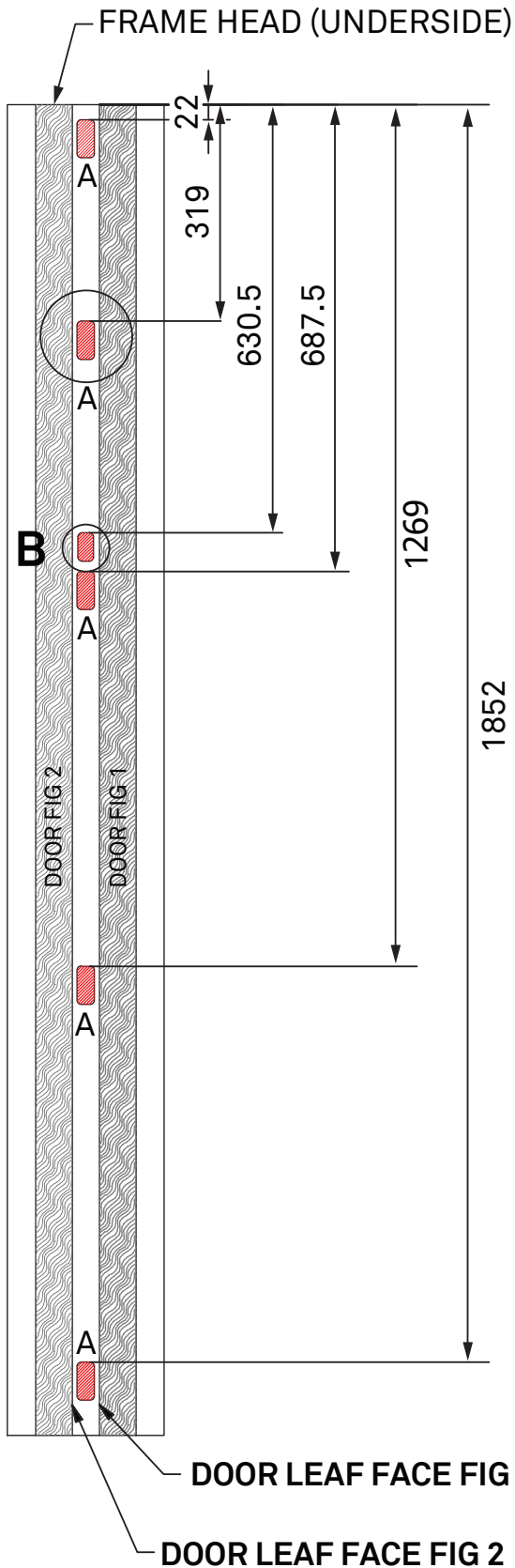

NOTE* MORTICE DETAIL ALLOWS +/- 2MM POSITIONAL ADJUSTMENT OF MOVASTOP RELATIVE TO DOOR FACE.

MOVASTOP FRAMEPLATE RECOMMENDED TO BE FITTED ON SITE WHEN DOOR LEAF IS IN LOCKED POSITION.

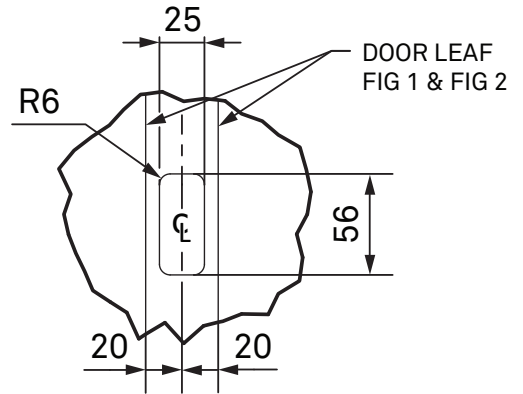

A (1:4)

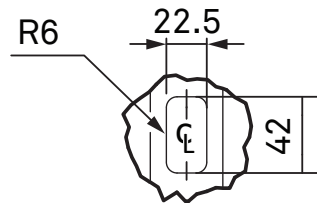

B (1:4)

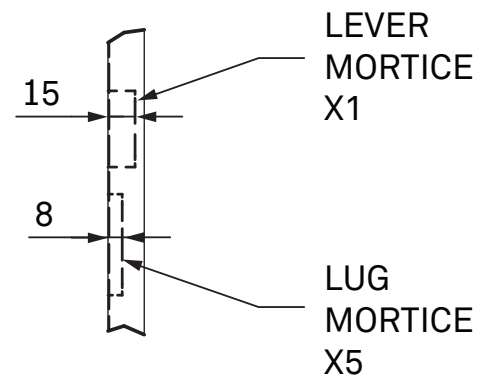

C (1:4)

Important Note: Safehinge Primera products are protected by Intellectual Property Rights including UK and Community Unregistered Design Rights, UK and Community Registered Designs and UK Patents and Patent Applications. For further details please contact Safehinge Primera Ltd.